

GAS CHEESE MELTER

QUEST Model QCM

QUEST's QCM unit is a salamander with a three position slide out wire rack. With efficient infrared gas burners, it has a 10 second warm up time and distributes even heat. Stainless steel sides, top and front are standard construction. The heavy duty QCM comes in three standard sizes. This unit can be mounted on a range, wall or counter and is easily serviced from the front.



QCM 36
MODEL ILLUSTRATED

Product Features

- Throttles to extremely low heat
- Versatile and durable
- Stainless steel front, top and ends
- Rapid heat-up time – 10 seconds, full heat – 2 minutes
- Two burners on 36" unit, each with accurate temperature control Hi-Low valves

Optional Features

- Available in 36" (914 mm), 24" (610 mm) and 18" (457 mm) widths
- SS under panel
- Flexible gas connector kit
- Counter mount kit
- Range mount kit
- Wall mount kit
- Extended wall mount kit

Quest- Gas Cheese Melter

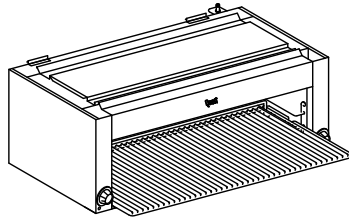

**MODEL QCM-36
SHOWN**

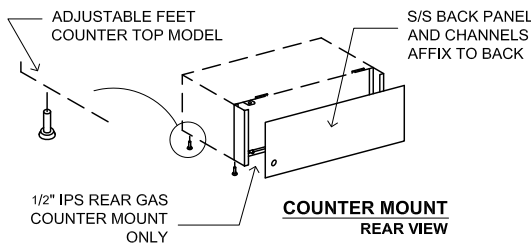
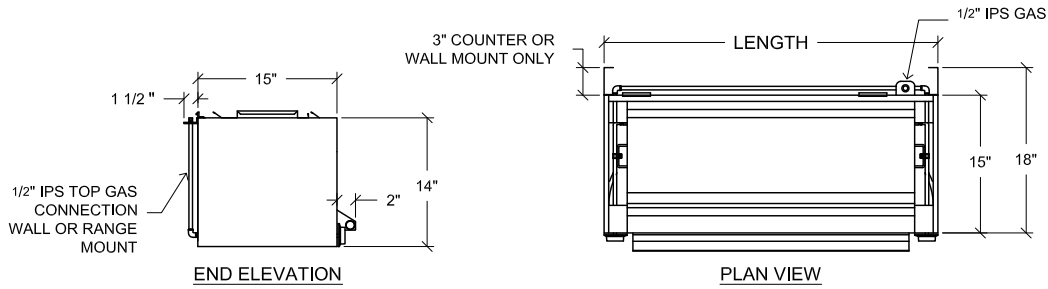

**COUNTER MOUNT
REAR VIEW**

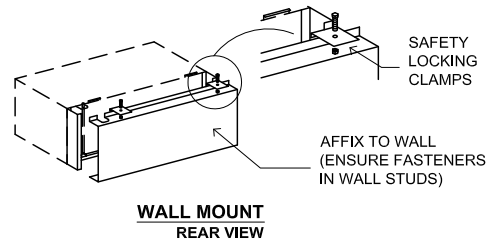

**WALL MOUNT
REAR VIEW**

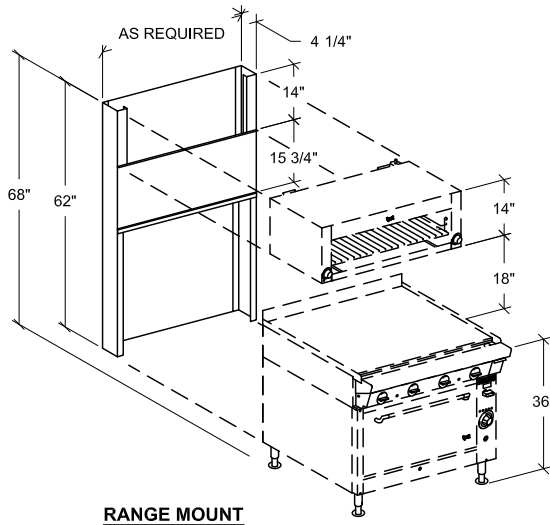

RANGE MOUNT

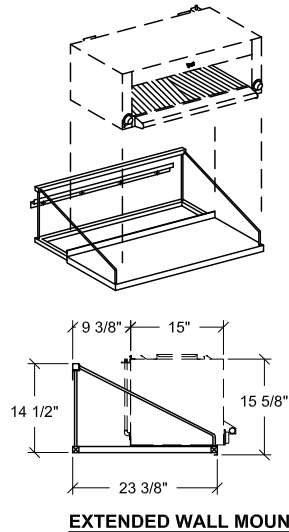

EXTENDED WALL MOUNT

MODEL	WIDTH (mm)	DEPTH (mm)	BODY HEIGHT (mm)	BTU'S	GAS LINE	SHIPPING WEIGHT	
						LBS	KGS
QCM 18	18" (457)	15" (381)	14 3/4" (375)	21,000	1/2" (13)	75	34
QCM 24	24" (610)	15" (381)	14 3/4" (375)	28,000	1/2" (13)	90	41
QCM 36	36" (914)	15" (381)	14 3/4" (375)	49,000	1/2" (13)	125	57

NOTE: Dimensions are accurate at time of publication but subject to change without notice. If sizes are critical consult the factory.



QUEST Metal Products Limited
889 Erin St, Winnipeg, MB R3G 2W6
Tel: 204.786.2403 Fax: 204.783.7598
Email: sales@questmp.ca

Distributed in Canada by:
Russell Food Equipment Ltd.
russellfood.ca