

DELUXE WOK RANGE

QUEST Model CHR

The QUEST Wok Range provides the intense heat required, yet is easily controlled, efficient and comfortable to operate. Each well has a specially designed combustion chamber, which concentrates the heat on the cooking area of the wok where it is required, and eliminates the burning of food on the wok's upper rim. The woks supplied are specially designed to prevent water from entering the

combustion chamber. Ranges can also be fitted with loose wok adapters. Sturdy construction assures operators of excellent performance and durability. The QUEST Wok Range is designed to fill the requirements of most Asian restaurants, large or small.



Product Features

- Heavy gauge stainless steel on all exposed surfaces
- Constructed with heavy angle frame throughout
- Stainless steel square tube overshef
- Lever gas valves for easy heat control
- Powerful jet burners generate instant heat
- Right hand integral sump/drain
- Deck wash down feature standard
- Standardly supplied with 22" bowls
- Approved for installation on combustible surface with a minimum clearance of 4" to the sides and 6" to back from adjacent combustible walls

Optional Features

- Higher heat per well
- Toss wok adaptors
- Boil pot
- Water fall wash down
- Water dam for deck washdown
- Custom lengths
- Custom depths

Quest - Deluxe Wok Range

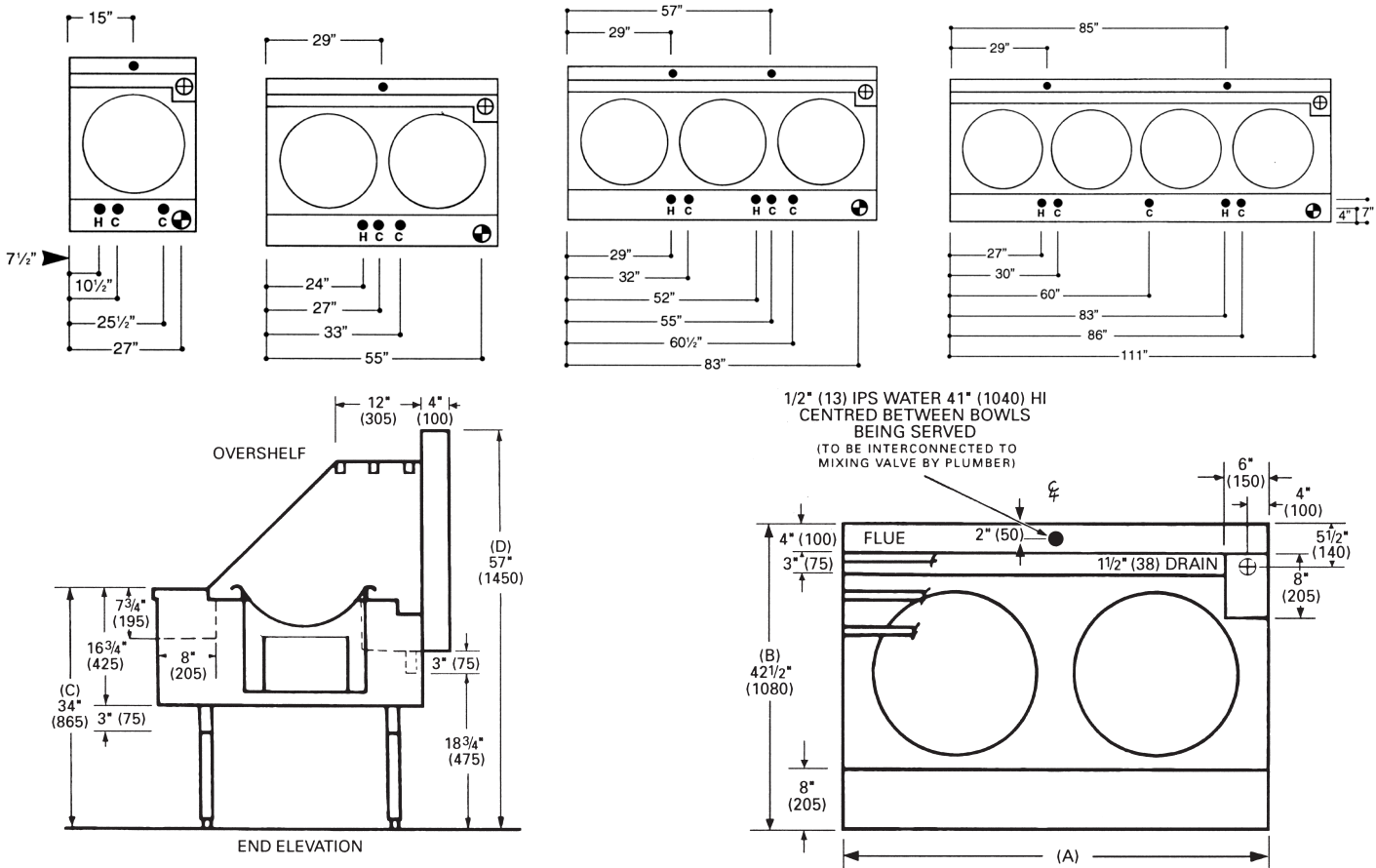

MODEL	NUMBER OF WELLS	NUMBER OF FAUCETS	DIMENSIONS (mm)				BTU'S	SHIPPING WEIGHT	
			A	B	C	D		LBS	KGS
CHR-1	1	1	30" (760)	42½" (1080)	34" (865)	57" (1450)	100,000	215	98
CHR-2	2	1	58" (1475)	42½" (1080)	34" (865)	57" (1450)	200,000	430	195
CHR-3	3	2	86" (2185)	42½" (1080)	34" (865)	57" (1450)	300,000	600	272
CHR-4	4	2	114" (2895)	42½" (1080)	34" (865)	57" (1450)	400,000	820	372

NOTE: I.P.S. – Iron Pipe Size (female)

- H C** **Mixing Valves** – ½" (13) IPS – located 7" (180) from front edge – 22" (560) high.
- C** **Washdown** – ½" (13) IPS – located 7" (180) from front edge – 22" (560) high.
- ⊕** **Gas Connection** – 1" (25) IPS – located 4" (100) from front edge – 16" (405) high. (Reversible to LH side.)
- ⊕** 1½" (38) IPS Drain - 17" (430) high

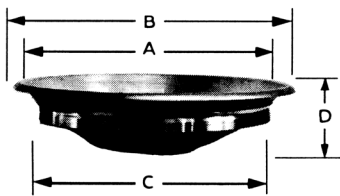

NOTE: 22" Bowls are standard

	A	B	Ct	D
20" (510) Bowl	20" (510)	21½" (550)	18⅞" (480)	5⅛" (130)
22" (560) Bowl	22" (560)	23½" (595)	18⅞" (480)	5⅞" (140)
24" (610) Bowl	24" (610)	25½" (650)	18⅞" (480)	5⅞" (150)
26" (660) Bowl	26" (660)	27½" (700)	18⅞" (480)	6⅜" (160)

NOTE: Dimensions are accurate at time of publication but subject to change without notice. If sizes are critical consult the factory.



QUEST Metal Products Limited
 889 Erin St, Winnipeg, MB R3G 2W6
 Tel: 204.786.2403 Fax: 204.783.7598
 Email: sales@questmp.ca

Distributed in Canada by:
 Russell Food Equipment Ltd.
 russellfood.ca